

The logo is centered on a dark brown background with a geometric, low-poly pattern. It features the word "Parma" in a large, white, cursive script font. Below it, the words "WOOD BIKE" are written in a smaller, white, bold, sans-serif font. The text is framed by a white laurel wreath that curves around the bottom and sides.

*Parma*  
WOOD BIKE

# SO, LET'S GO?

	PAGE
1. SUMMARY	2
2. PHOTO GALIERY	3-7
3. CONCEPT	8
4. PART OF YOUR LIFE: HOW IT STARTED	9
5. THE BIKE PARTS (DETAILS)	10
6. HOW GOOD IT IS	10
7. YOUR STYLE: COLORS AND FINISHING	11
8. ORIGINS	12
9. ERGONOMICS	13
10. TECHNICAL SPECIFICATIONS	14
11. TESTING YOUR COMFORT	14
12. FROM ROAD'S COMPANION TO HOME'S LITTLE DARLING	15
13. STARTING THE FUN: SET-UP GUIDE	16
4. SETTING THE HOLDERS UP	17
5. PRESERVATION: KEEP YOUR PASSION CLEAN AND FRESH	18
6. WARRANTY POLICY	18



Designed by  
Louro Parma Júnior













## CONCEPT

*DO YOU KNOW ADVENTURE? SO, THAT'S THE SPIRIT!*

*" THE DESIRE TO VENTURE INTO THE CREATION OF SOMETHING THAT COULD BE A DIRECT PART OF YOUR LIFE WAS THE FIRST INGREDIENT ADDED TO THE FORMULA THAT CREATED THIS NEW CONCEPT.*

*TO ACHIEVE THE DIVERSITIES BETWEEN BEING RELAXED OBSERVING HARMONIOUS FORMS AND BEING THE ESSENCE THAT MOVES THE MUSCLES AND DRIVES YOUR INSTINCT OF FREEDOM!*

*A TENUOUS LINE BETWEEN THE HAVING AND BEING ABLE TO: TO HAVE A FAVORITE OBJECT OF DECORATION AND TO BE ABLE TO MAKE IT YOUR ROAD'S COMPANION.*

*THE DESIRE TO LAY ON THE COUCH JUST LOOKING, OR GETTING UP FROM IT, LEAVE HOME AND STILL BEING ABLE TO TAKE US WITH YOU. "*



# *PART OF YOUR LIFE!*

*HOW EVERYTHING STARTED*

*“ THE DESIRE TO VENTURE INTO THE CREATION OF SOMETHING THAT COULD BE A DIRECT PART OF YOUR LIFE WAS THE FIRST INGREDIENT ADDED TO THE FORMULA THAT CREATED THIS NEW CONCEPT..”*

*“TO ACHIEVE THE DIVERSITIES BETWEEN BEING RELAXED OBSERVING HARMONIOUS FORMS AND BEING THE ESSENCE THAT MOVES THE MUSCLES AND DRIVES YOUR INSTINCTS OF FREEDOM!”*

*“A TENUOUS LINE BETWEEN HAVING AND BEING ABLE TO: TO HAVE A FAVORITE OBJECT OF DECORATION AND TO ABLE TO MAKE IT YOUR ROAD'S COMPANION.”*

*“THE DESIRE TO LAY ON THE COUCH JUST LOOKING, OR GETTING UP FROM IT, LEAVE HOME AND STILL BEING ABLE TO TAKE US WITH YOU.”*

“I have bike's hoarding as a hobby and the love from working with wood. So I had decided to bring together these two facts that are part of my life and then create this piece. When I started the development of the part, I had in mind the impact that it would cause in the lives of our customers. What provided the idea of making the bike and made it become a project was the possibility to be able to get into our customer's life, even outdoors.”

The author of the work is Louro Parma Junior and he tells that the traces were based on organic forms and uniformed finishing, with every detail designed to adapt ergonomically to its use, prioritizing its comfort. It's clear that high quality materials could not be missed, considering the know-how of Parma's furniture manufacturing, which works with wood for over 50 years!

With all the beauty that its forms had been given, it becomes the number one candidate to be the most featured decorative object and be most favorite within the house, despite being a wonderful decorative object, it does not lack anything in its functionality, practicality and comfort categories.

For us, having our brand present in your leisure moments is a great satisfaction, it's a true sense of a job well done.

It's a pleasure, we are the Parma Wood Bike!







## HOW GOOD IT IS

The PWB Freedom is exclusively handmade in solid wood from the species TeakAsian (*Tectona grandis*), which is used in the nautical sector for the manufacture of furniture and decks of yachts and sailboats. Also used in manufacturing for external areas furniture. The TeakAsian is a lightweight, durable and stable wood.



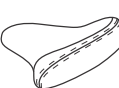

In the making, we use the bonding process to compensate the wood fibers, in order to give a better resistance to the parts. Fittings and joints were sized and located in strategic positions in order to get stubbornly stuck with structural adhesive.

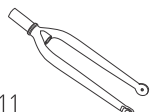

To ensure the durability of the wood, a waterproof insulator is applied to protect it from any moisture. A resin (a product used on yachts furniture) is applied to the polyester to conclude the finishing. (a product used on yachts furniture) and a high-gloss varnish, giving the wood a deep and wet sheen.

The aluminum pieces: fork, handlebar table, hoops, crown, rest and levers are painted with an Italian ink color effect, and it can be customized in up to 9 colors according to our finishing palette (p. 21).

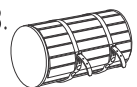
- 1.  **SHIMANO NEXUS HUB GEARS**  
3 AND BRAKE AGAINST PEDAL
- 2.  **FRONT BRAKE DISC**
- 3.  **BIKE SEAT WITH RUBBER SPRINGS**  
COATED IN CUSTOM LEATHER
- 4.  **WOODEN PEDALS**  
MULTILAYERED
- 5.  **WOODEN HANDLES**

- 6.  **HANDLEBAR ALUMINUM**
- 7.  **RAY WOODEN STAR**
- 8.  **TIRES RUBENA CITY CHOPPER 26" X 2.0**
- 9.  **ALUMINUM RING 26" DOUBLE LAYER**
- 10.  **TABLE WOOD TEAK ASIAN**

- 11.  **FORK IN ALUMINUM**
- 12.  **CENTRE STAND WITH HEIGHT ADJUSTMENT**
- 13.  **SADDLEBAG NATURAL BAMBOO FIBER SADDLE**
- 14.  **WALL SUPPORT**

- OPTIONS**
- 15.  **VERTICAL MDF SUPPORT AND TEAK BLADES**
  - 16.  **NATURAL BAMBOO FIBER BASKET**

YOUR STYLE



## COLORS AND FINISHING

BUILDING YOUR STYLE

### METAL PART

The aluminum parts (fork, handlebar table, hoops, crown, rest and lever) are painted in an Italian ink color effect and it can be customized according to the customer's taste. At the side is our colors' pallet, so you can visualize it better.

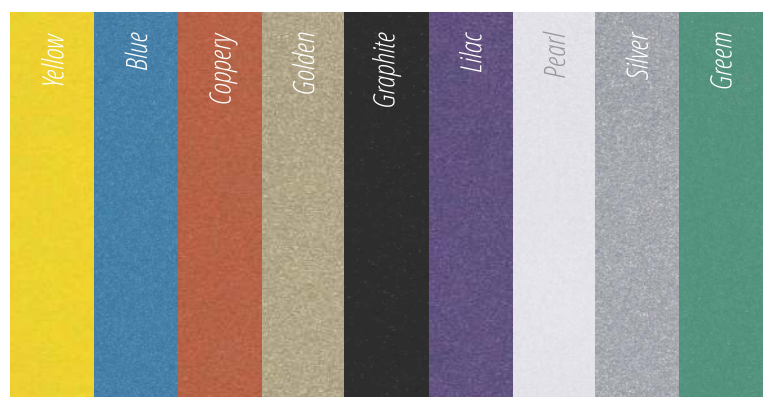

### WOODEN PARTS

The pieces of wood, frame, beams, handles and pedals are finished based on polyester resin and a finishing in self-gloss varnish.

Teak Asian





## ECOLOGICAL SINCE ITS SPROUT

All wooden parts of the PWB Freedom are shaped exclusively by hand, with Teak wood (**Teak Asian**), of an Asian origin tree.

We, with the awareness of no harm to the environment, chose Floresteca as our supplier of the Teak wood.

Floresteca is a company that has a huge environmental awareness. Among its practices, there are a monitoring of water resources, solid waste generation and environmental impacts of forest operations and the subsidy to the improvement of management techniques of teak forests. In the social area, the company establishes channels of communication with communities affected by its management, in order to measure their social impacts and/or take corrective measures if necessary, as well as strengthen the positive aspects of its influence.

Also Floresteca promotes a planting of forest management in the cultivation of Teak, making sure that you get a completely legal product that contributes to the non-deforestation of natural forests.

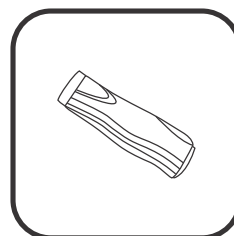
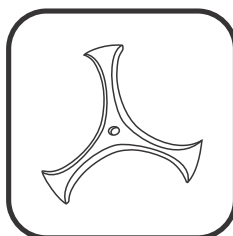
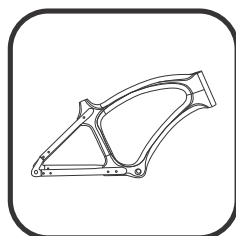



## ERGONOMICS

CAUTIONS THAT WE HAVE TO TAKE TO PRESERVE YOUR COMFORT WHILE USING THE PWB FREEDOM.

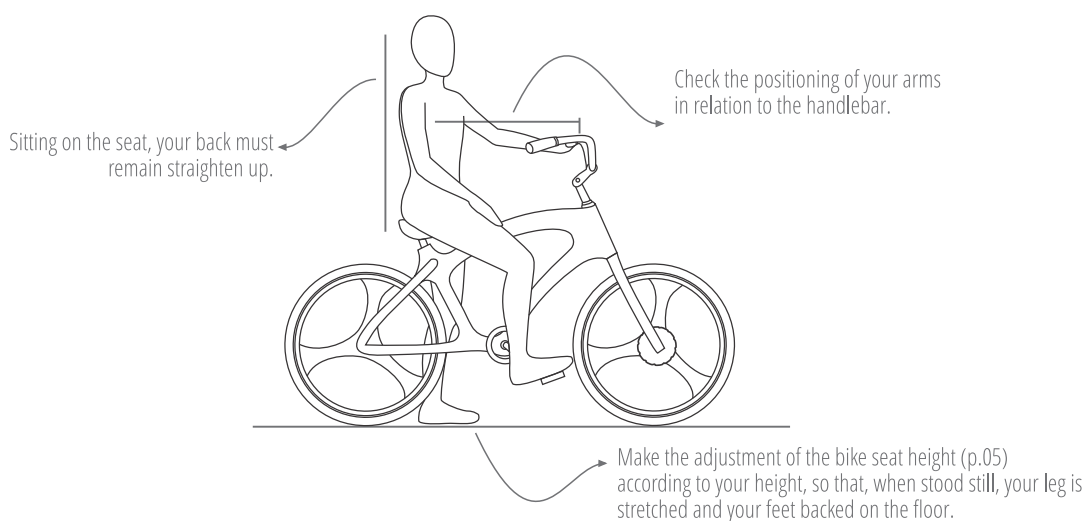

A PERFECT BIKE RIDE HAS ITS OWN DEFINED MEASURES TO PRESERVE THE USER COMFORT.

THAT'S WHY THE PWB FREEDOM COMES WITH AN ADJUSTABLE SEAT AND HANDLEBARS. TO KEEP YOUR POSTURE CORRECT WITH YOUR BACK STRAIGHT AND ARMS SUPPORTED ACCORDING TO THEIR HEIGHT IN RELATION TO THE BIKE. ALLOWING YOU TO SUPPORT YOUR FEET ON THE GROUND COMFORTABLY.

THESE FEATURES REDUCE THE PROBABILITY OF CAUSING POSSIBLE PHYSICAL DAMAGES TO ITS USERS.

## TECHNICAL SPECIFICATIONS

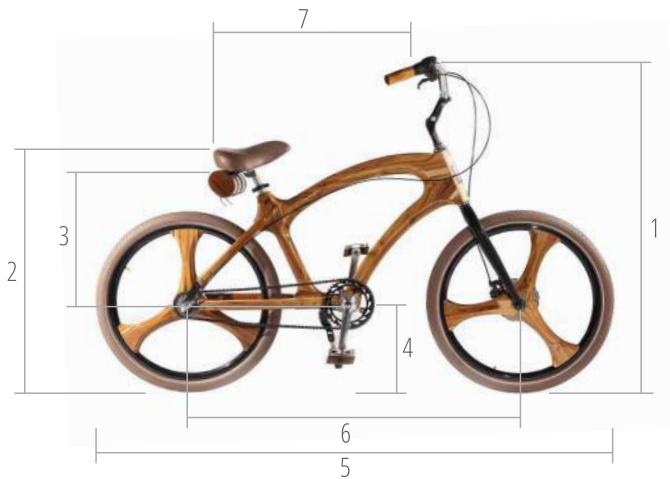

### WRAPPED FOR GIFT

The PWB Freedom has arrived at your home wrapped and isolated properly, always in order to avoid damage while transporting.

Pre assembled for transport facilitation.

The disassembled parts are the handlebars, which is attached to the frame; the pedals, which are packaged separately and stuck the fork and the front wheel, which must be attached to the fork through the hub with locking (Set-up Guide p.30), all within a case that should be opened carefully.

**-Please Note:** Be careful when cutting the tape that holds the protections used in the packaging because the sharp object should be handled with attention in order to avoid scratching the wood.

**-With the Freedom PWB comes:** 1 Wall Bracket, 1 Pannier, 1 Flannel and 1 Wax Tube to help you clean your bike.

### MAIN MEASURES

1. Total height	1180 mm
2. Bike seat minimum height	900 mm
3. Bike seat minimum height/ Central axis	500 mm
4. Height of the central axis	330 mm
5. Total length	1850 mm
6. Distance axes	1170 mm
7. Bike seat minimum distance/ Handlebars	650 mm

### PACKAGE MEASURES

1. Length	1550 mm
2. Height	940 mm
3. Width	300 mm

### BIKE WEIGHT

17,6 Kg

### PACKAGE WEIGHT

25 Kg

### TIRE PRESSURE

35 a 45 Psi

Obs.: The measures described above are approximate and may be changed without prior notice, in order to bring customer improvements.



## TESTING YOUR COMFORT

*Our greatest concern is your well-being. So, before even presenting the bike PWB FREEDOM to you, it was tested in laboratory into several strength tests.*

*Among these tests, it was subjected to a cycle of fatigue and endurance tests with load levels increased gradually with 110Kg, 130kg, 160Kg, 180Kg and 200Kg without presenting any damage or cracks in its structure.*

*Proving the quality, safety and durability of this product, that will be part of your leisure time!*



*FROM ROAD'S COMPANION*

*TO HOME'S LITTLE DARLING*

Just as the concept implies:

"The desire was to create something that could be part of your life [...] " that is what motivated us.

Among with the PWB Freedom goes a horizontal wall bracket (photo) so you can attach it to your favorite place indoors and make it your favorite decorative object. So we fulfilled our aim to make you relax watching harmonious forms" and in addition " to be the essence that moves the muscles and move your instinct of freedom! "



**WALL  
SUPPORT**

**"A TENUOUS LINE BETWEEN HAVING AND BEING  
ABLE TO: TO HAVE A FAVORITE OBJECT OF DECORATION  
AND TO ABLE TO MAKE IT YOUR ROAD'S COMPANION."**

PARMA WOOD BIKE



## STARTING THE FUN

### THE SET-UP GUIDE

#### YOU WILL NEED:

You will find the necessary tools to assemble your PWB Freedom on the Bamboo rear bag.



5mm hex key



15mm wrench

#### 1.HANDLEBAR

- 1 Use a 5mm hex key that comes inside the saddlebag and remove the mounting table of the handlebars;
- 2- Attach the handlebar adjusting the inclination according to the height of the rider;
- 3-Do fixing by giving grip to cross-screws.

#### 3.PEDALS

1. Identify the side of each pedal according to its recording existence at the end of the shaft thereof, with L (left) and R the left (right) to right;
- 2- Start the fitting of the thread with your fingers and make the grip with a wrench 15mm coming in the saddlebag.

#### 2.FRONT WHEEL

1. Insert the axle on the fork dropout;
- 2- Open and hold the locking lever in the position aligned with the axis;
3. Tighten the nut (clockwise) on the other side of the shaft, until it stops turning;
- 4- Push the locking lever in the sense that it gives pressure until you get 90° from the axis. If the pressure is too high, release the lever and turn the nut counter-clockwise a half turn.

#### 4.BIKE SEAT

- 1- With the lever in the opened position, adjust the bike seat height in a way that when it is stood still it can have a perfect support of the feet on the ground;
- 2- Close the lever to lock the seatpost of the bike seat again.





## ASSEMBLING THE SUPPORTS

### **HORIZONTAL SUPPORT**

The horizontal wall bracket comes with your bike. With it you can make your PWB Freedom favorite object of decoration in your house. 2 people are required to get the support.

1. Measure the wall at the desired height;
- 2- There are two pieces of support for the wheel, first put secure the support of the rear wheel;
- 3- With the help of a person place the rear wheel resting on the support fixed to measure the position of the support of the front wheel;
- 4 Put the bracket of the front wheel;
- 5 With another person put the wheels on supports attached.
6. Engage the dropout on the pedal and support the wood on the wall and mark the hole;
- 7 Drill the wall according to the marking and fix the central support;
- 8 - Support PWB Freedom of the supports and engage the dropout on the pedal.

### **VERTICAL SUPPORT \***

The vertical wall bracket is an option that may be purchased separately and that will complete even more your environment.

1. Place the stand on the floor, leaning against the wall;
2. The bracket is mounted on the wall by one (1) screw bushing;
3. Before making the hole, make sure the support is flat on the floor and on the wall;
4. Use drilling upper part support to make the hole on the wall;
- 5- Drill, place the bushing place the holder and insert the bolt, tighten with the key allen 5mm (the same used in assembling the bike).

*Obs.: Screws, bushings and allen key, lying inside the package.  
\* Sold separately.*

#### ***CLEANING***

To clean the bike, we do not recommend washing it with water, so do the cleaning with a clean flannel to clean the dust and/or wax it with Sonax Polish & Wax to keep its shine. which goes inside the saddlebag of the Freedom PWB a flannel and a wax tube to assist you in maintaining the cleanliness and preservation of the wood.

#### ***MAINTENANCE***

In case of damaging the finish of the wood, depending on its risk of depth, it can be fixed with a sanding process with sandpaper grain water in 1200, making then through the polishing process with mass polishing (the same used in the automobile tracking) after that using a wax Sonax Nano Polish and then Sonax Polish & Wax to give back its shine.

#### ***SPARE PARTS***

Most of the parts are easily found in the market.

In case of any special needs we can meet on spare parts, such as the pedals, frame, spokes and handles that are manufactured by us.

## ***WARRANTY POLICY***

---

We give a five (5) years warranty against manufacturing defects on the frame and the hoops in case of production failure or material. Only the defective part will be replaced.

However there are some points that should be noted:

1. Should not be considered damages due to misuse or normal friction like the brakes and tires.
2. Breaking parts due to abuse like to cram, beat, overweight and/ or accidents are also not included in this warranty.
3. The warranty is limited to the first owner, so if the bike is sold to third parties is will automatically and your warranty.
4. Breakdown and changes made in the material due to improper transportation, storage in humidity, among others, will not be considered manufacturing damages.
5. In case of the replacement of some parts for manufacturing damages within the warranty period, it will continue to run normally at time of five (5) years from the purchase, with no changes or extensions.
6. The warranty period shall be counted starting from the day that chit is filled.

Warranty rightfrom the factory.

Contact      E. [itbg@itbg.com.br](mailto:itbg@itbg.com.br)  
                  P. +55 11 9 9004 4299